

Alert - Some parts for the suffix A transfer case are no longer available. Gears special to the suffix B transfer case are no longer available. We expect Suffix B special parts to become unavailable over the next few years. If you need parts that are no longer available we suggest replacing your transfer case with a suffix C or newer version.

Save your old shims for reuse - Land Rover has discontinued just about all the transfer case shims.

Transfer Case Series II, IIA, III

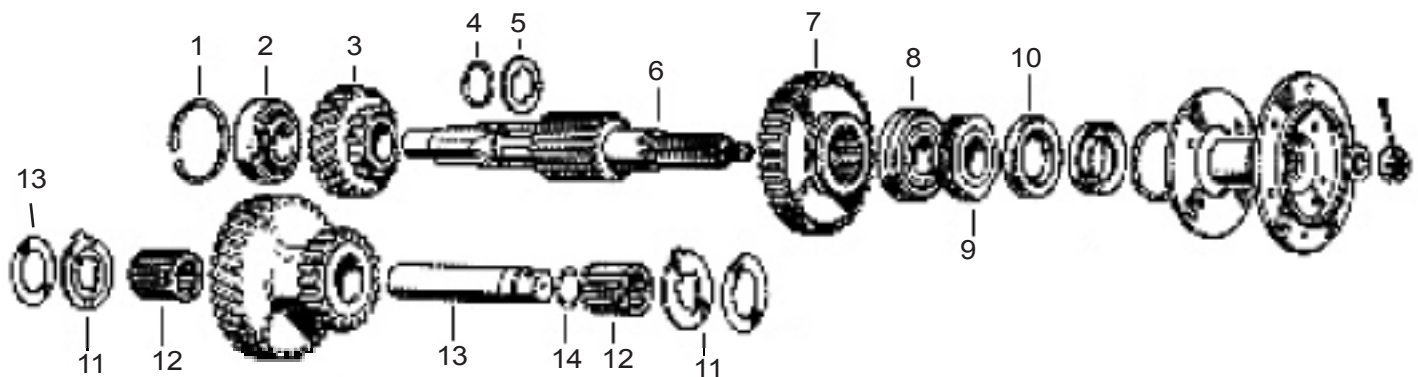

Main case components

1	Circlip, for front output shaft bearing	90217526
2	Bearing, front output shaft	217490
3	Gear, high range	218243
4	Circlip	CCN122
5	Thrust washer	90217488
6	Output shaft, Ser. IIA	235985
	Output shaft, Ser. III	591429
7	Low range gear, Suffix C & newer	532979
8	Bearing, rear output shaft	90217512, 90217512P
9	Speedometer drive gear	FRC1536
10	Oil Seal, output	FRC1780
11	Thrust washer (2 req)	521328
12	Roller bearing (2 req)	599869
13	Shaft, intermediate gear	594195
14	O- ring	532323

Front output housing components

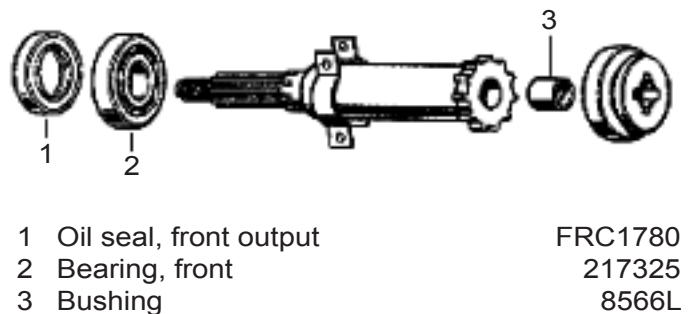

1	Oil seal, front output	FRC1780
2	Bearing, front	217325
3	Bushing	8566L

Transmission output gear components

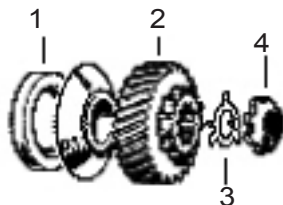

1	Oil seal, transmission to transfer case	236305
2	Gear, Main shaft output	218244
4	Lock washer	217476
5	Nut	217477