

Drive Shaft & Brake

29

Hand Brake Assembly

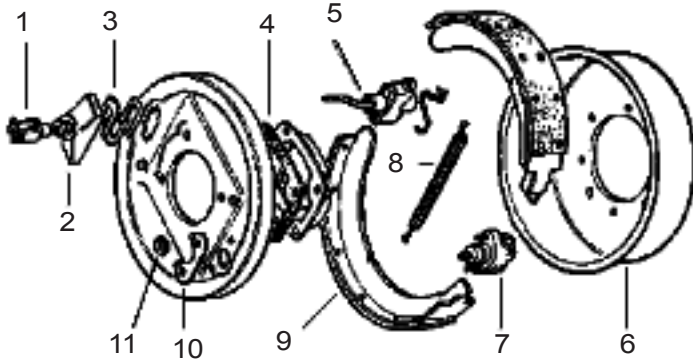

NOTE: Most parts for the early style hand brake are no longer available. The complete late style brake assembly will fit the early transfer case. The easy way to check to see if you have an early or late style brake is to look for a "V" notch cut into the middle inner edge of the shoes. The "V" indicates late style shoes.

1	Clevis	215809
	Clevis pin	216421
2	Expander boot	515466
3	Packing plate (expander unit fixing)	515470
	Locking plate (expander unit fixing)	515467
	Retaining spring (expander unit fixing)	515468
4	Gasket, oil catcher	561856
5	Expander unit (late style)	515366
6	Brake drum	274423
7	Adjuster repair kit (late style)	515924
8	Spring	FRC8549
9	Shoes (late style)	STC3821
10	Lock washer for adjuster	542515
11	Nut, adjuster	NH604041L

Drive shafts



Front, 4 cyl, 88 & 109	STC1898
Rear, 88	FRC4907
Rear, 4 cyl, 109 with Rover rear end	STC573
Rear, 4 cyl, 109 with Salisbury rear end	FTC3245

Bolt for drive shaft (8 req)	509045P
Lock nut for drive shaft (8 req)	NZ606041L



Boot, protects drive shaft slip joint	276484
---------------------------------------	--------

U-Joints for Drive Shafts



2-5/16 Cap to Cap	RTC3458
3-7/32 Cap to Cap	RTC3346

Breathers, Axle Housing

Ball valve style breather, All thru 1975	515845
Remote breather, 1976 & on	595473
Fits all early axle housings: connector and tube	

Note: The ball style breather often sticks closed, even soon after cleaning. This causes oil to be vented out the differential pinion seal.

We recommend replacing old ball style breathers with the newer style breathers.

HELP LINE: 661-257-8634
24 HOUR FAX: 661-257-9765



Check our web site for our **Specials**
www.britishpacific.com