

Salisbury Differential

Fitted as standard to the front and rear of the 109 1 ton model and to rear of 109's starting 1972, after the 109 was no longer offered for sale in North America. The Salisbury is stronger than the Rover unit and is a bolt in upgrade. Many have been added to the rear of earlier 109 Land Rovers by their owners. It is worth checking to see which differential your truck has before ordering parts.

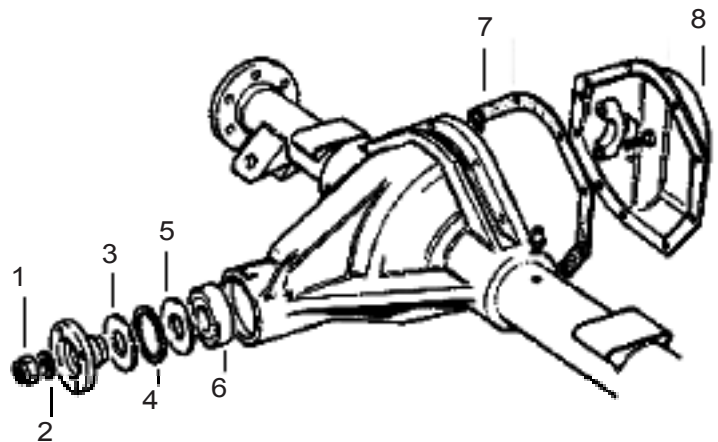
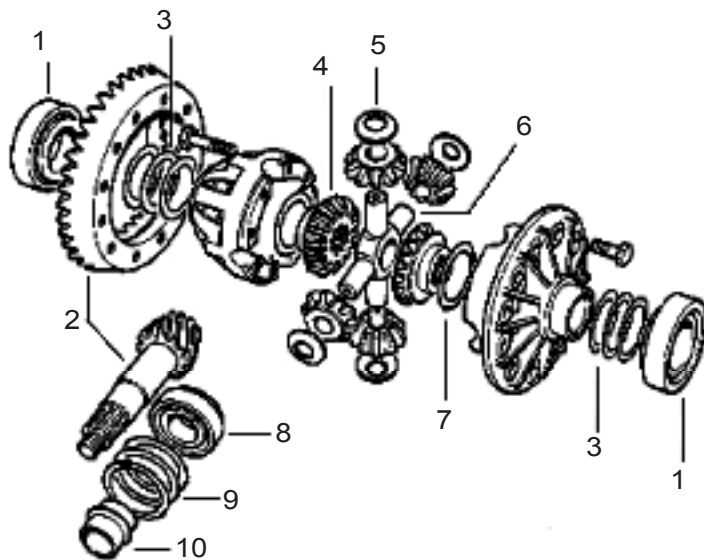

- | | |
|--|----------|
| 1 Nut, pinion | 90608545 |
| 2 Washer, thick (special order item) | 607357 |
| 3 Seal, pinion | AEU2515 |
| 4 Gasket between pinion seal & housing | 607183 |
| 5 Washer, oil thrower (special order) | 607182 |
| 6 Bearing, outer pinion | 607181 |
| 7 Gasket | RTC1139 |
| 8 Back plate (special order item) | RTC844 |

- | | |
|--|----------|
| 1 Bearing, carrier (2 req) | 607187 |
| 2 Ring & Pinion gear set | RTC1392 |
| 4.7 ratio | AEU1488 |
| 3.54 ratio | |
| 3 Shim, .0003" | 607188 |
| Shim, .005" | 607189 |
| Shim, .010" | 607190 |
| Shim, .030" | 607191 |
| 4 Differential gear kit | RTC4488 |
| (matched set of 6 spider gears & 6 thrust washers) | |
| 5 Thrust washer (4 req) | 607168 |
| 6 Spider spindle | 90607170 |
| 7 Thrust washer (2 req) | 607169 |
| 8 Bearing, inner pinion | 607180 |
| 9 Shim, .003" | 607177 |
| Shim, .005" | 607178 |
| Shim, .010" | 607179 |
| 10 Bushing | 607197 |

ARB Air locker differentials



- | | |
|--|---------|
| Air Compressor Kit. | RDCKA |
| Rover axle differential Kit | RDO3 |
| Bearings (2 required with RD03 diff kit) | RTC3426 |
| Salisbury axle Differential Kit. | RD32 |
| Ring Gear Spacer (for 4:70 gears) | RDO3A |
| Spacer bolts for RD03A | 576521 |
| Washers for RD03A | 593693 |
| Tire Pump Up Kit (optional for tire inflation) | PUK |