

IPF bulbs



IPF halogen bulbs are sold individually.

- | | |
|----------------------------------|-----------|
| 55/60 watt | HHC126055 |
| 80/110 watt | HHC121080 |
| Philips Vision Plus H4 55/60, pr | GBK002 |
| H3 55 watt single filament | HBJ-12055 |



Finally, complete off road lighting kits priced at what some folks charge for one light! They are ideally suited for Land Rovers, due to their low current draw and rugged construction.



IPF 968CS Series

An affordable outfit for any application. 55 watt H3 bulbs, 6" hardened glass lenses, includes all hardware, wiring, relay, fuse, switch, and covers. The kit is easily installed, and are perfectly suited for any of our brush bars, ARB bull bars, or any Land Rover bar with light tabs. Beams have a conical projection, with the tip out front. They radiate 26' on either side of the light, and project out 265'. They're perfect for long dark highways or twisty trails. **968CS**

Genuine Land Rover Work light

Genuine waterproof work light with mounting kit, wiring, and internal and external switches. H3 halogen bulb, swivel base. Looks great on racks or the rear body. RTC8921AA



Head lamp bucket & rim

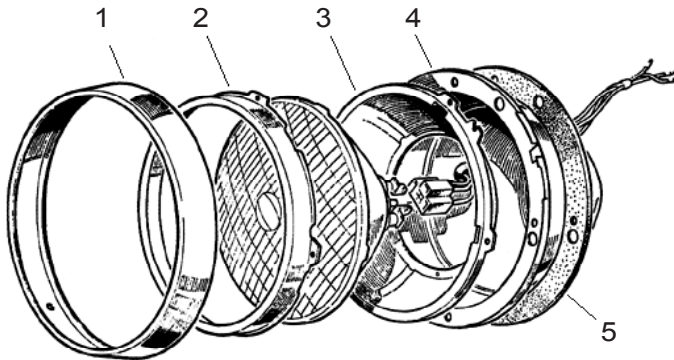

- | | |
|--|---------|
| 1 Trim ring, Ser. II, IIA to '68 | 142001 |
| 2 Retaining ring | PRC7992 |
| 3 Bucket, inner | 560-215 |
| 4 Bucket, outer | 144-797 |
| 5 Seal, bucket to body | 531586 |
| Head lamp socket with leads | BW141 |
| Adjuster assy set (1 set per lamp) | 147-015 |
| (screws and stops to adjust head lamp) | |

IPF900XSD Extreme



Extreme Service Set. Contains two 69 watt H9 lamps, one for fog, one for distance (driving). These have steel housings and hardened lenses to take rough treatment: the lights and wiring are sealed for submersion in water for up to 2 minutes! Includes hardware, covers, and wiring, this light pair is the perfect solution for any Land Rover. **900XSD**

HELP LINE: 661-257-8634
24 HOUR FAX: 661-257-9765



Check our web site for our **Specials**
www.britishpacific.com